

Dimmable, Low Noise, Dual EL Lamp Driver Demoboard

General Description

The Supertex HV861DB1 demoboard contains all the necessary circuitry to demonstrate the features of the HV861 dual EL Lamp driver.

Simply connect it to a power supply and a lamp as shown in Figure 1.

A 2.2μF capacitor is connected between V_{REF} and GND. It allows the lamp to slowly (in about 400ms) brighten up/dim down during power up/power down. The dimming feature is common to both lamps.

Specifications

Parameter	Value
V_{DD} input voltage:	2.5V to 4.5V
V_{IN} inductor supply voltage:	3.2V to 4.2V
Typical supply current:	28mA
Lamp size:	4.5in ²
Lamp frequency:	188Hz
Converter frequency:	98kHz

Board Layout



Actual Dimensions: 26mm x 24mm

Connections:

EN1 and EN2: Lamp Selection

CMOS logic inputs which enable/disable the lamp drivers. When EN1 is connected to V_{DD} /GND, Lamp 1 (EL1) will be ON/OFF. When EN2 is connected to V_{DD} /GND, Lamp 2 (EL2) will be ON/OFF.

V_{DD} : IC Supply

Supplies the HV861 EL driver IC. The supplied circuit is optimized for 3.0V operation.

V_{IN} : Inductor Supply

Supplies the high voltage power converter. The demoboard is optimized for 3.2V to 4.2V operation

GND: Circuit Ground

Connect to V_{DD} and V_{IN} negative terminals. Supply bypass capacitor for both V_{DD} and V_{IN} are provided on the demo board. External supply bypass capacitors are not necessary.

EL1 and EL2: Lamp Connections

Connects to Lamps 1 and 2.

COM1 and COM2: Lamp Connections

Connects to the other side of Lamps 1 and 2.

Note: All of the above connections must be made before powering up the supply voltages. The V_{REF} pin should not be touched after power-up.

Figure 1: HV861DB1 Circuit Schematic

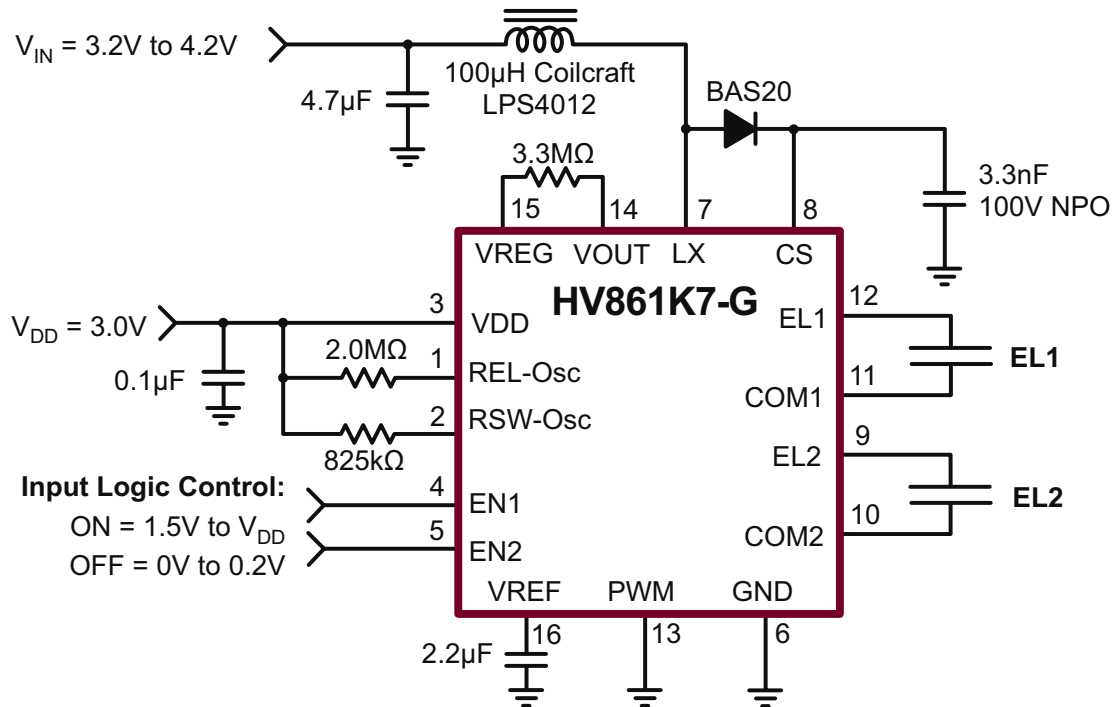

Typical Performance

Load size: EL1 = 10.8nF, EL2 = 9.3nF, total lamp size ~4.5in²

V_{DD} (V)	V_{IN} (V)	Lamp	I_{IN} (mA)	V_{CS} (V_{PEAK})	f_{EL} (Hz)	Lamp Brightness (cd/m ²)	
						EL1	EL2
3.0	3.2	EL1 ON	21.3	93	188	14.6	-
		EL2 ON	14.8			-	17.8
		EL1 & EL2 ON	30.9			13.9	16.6
	3.6	EL1 ON	18.8	93	188	14.7	-
		EL2 ON	12.8			-	17.9
		EL1 & EL2 ON	27.5			14.4	17.4
	3.8	EL1 ON	17.8	93	188	14.8	-
		EL2 ON	12.0			-	18.0
		EL1 & EL2 ON	26.3			14.6	17.6
	4.0	EL1 ON	16.9	93	188	14.8	-
		EL2 ON	11.4			-	18.0
		EL1 & EL2 ON	25.0			14.6	17.7
4.2	EL1 ON	16.0	93	188	14.9	-	
	EL2 ON	10.8			-	18.1	
	EL1 & EL2 ON	24.0			14.7	17.8	

Bill of Materials

Component	Description	Package	Manufacturer	Part Number
L_X	100 μ H shielded inductor	---	Coilcraft	LPS4012-104MLB
D1	200V fast recovery diode	SOD-323	Diodes Inc.	BAS20HT1
C_{IN}	4.7 μ F, 10V ceramic chip capacitor	0805	Any	---
C_S	3.3nF, 100V, NPO chip capacitor	0805	NOVA CAP	0805N332K101NT
C_{DD}	0.1 μ F, 16V ceramic chip capacitor	0805	Any	---
C_{REF}	2.2 μ F, 16V ceramic chip capacitor	0805	Any	---
R_{EL}	1% 2M Ω chip resistor	0805	Any	---
R_{SW}	1% 825k Ω chip resistor	0805	Any	---
R_{REG}	1% 3.3M Ω chip resistor	0805	Any	---
R_{PWM}	0 Ω chip resistor	0805	Any	---
U1	EL driver IC	16-Lead QFN	Supertex	HV861K7-G

Note:

The above circuit may be optimized further based on specification of the lamp used.

Supertex inc. does not recommend the use of its products in life support applications, and will not knowingly sell them for use in such applications unless it receives an adequate "product liability indemnification insurance agreement." **Supertex inc.** does not assume responsibility for use of devices described, and limits its liability to the replacement of the devices determined defective due to workmanship. No responsibility is assumed for possible omissions and inaccuracies. Circuitry and specifications are subject to change without notice. For the latest product specifications refer to the **Supertex inc.** (website: <http://www.supertex.com>)